

# SPINNER II<sup>®</sup>

OIL CLEANING CENTRIFUGE

**Model 600 HD** 16 gpm at 60 psig  
6,000 cc Dirt Capacity

Installation Instructions

Parts List

Service Instructions



### Oil Supply to Centrifuge

Oil supply should, in general, be taken from the highest pressure, hottest source available on the dirty side of the full-flow oil filter. A 3/4-in. pipe or #12 hose supply line should be used with a full-opening ball valve installed at the centrifuge oil inlet so that the unit can be isolated for service without shutting down the engine. Preferred pressure is 60 to 80 psig but the Spinner II centrifuge will operate efficiently at 40 to 90 psig. Below 35 psig, an internal idle cut-out valve closes to prevent low oil pressure during low-speed operation.

### Clean Oil Return to Sump

#### Level Control Base (LCB) — Preferred

The air-operated control in the Part No. 71602 LCB permits the Spinner II centrifuge to be installed on the frame rail, base plate or deck in any convenient location near the engine, above or below the sump oil level. The clean oil drain line to the sump should be 1/2-in. diameter minimum *unrestricted* hose or pipe to a 1/2-in. connection located above oil level if possible — alternate oil-fill openings or drilled-and-tapped holes in crankcase doors are possibilities. Below-oil-level return drain requires that a 1/2-in. low opening pressure check valve be located at the LCB oil discharge to prevent back-flow when the centrifuge is being serviced. Only check valves are permitted in the drain line — *shut-off valves must never be used*.

**Control Air Supply.** The control in the LCB maintains the proper oil level for maximum centrifuge speed and efficiency. Compressed air to operate the LCB may be obtained from any 2 to 125 psi unregulated air source, as 88.15 SCFM is minimal. Any inlet pressure exceeding 125 psi must be regulated using P/N 71050. This regulator should be installed as shown, with a 1/4-in. air line connected to it using liquid sealant on threaded connections. In the absence of compressed air, it may be possible to use bleed air from the engine turbocharger or air from a positive displacement scavenging blower. This requires modifying the LCB for low-pressure operation. Remove regulator P/N 71050 and connect air supply directly into cartridge P/N 71603. This revised P/N 71603 is marked with wide band on hex. Use of 71246 Pre-Filter is recommended.

**Assemble** Spinner II unit with Part No. 70916 Seal to Level Control Base. Install Regulator. See *parts list on opposite page*.

**Using Gravity Drain — Engine Mounted Only —** For gravity drain without the Level Control Base, the Spinner II centrifuge must be close-coupled to the sump with an unrestricted 4-in. drain returning above the normal sump oil level. The drain line must be sloped downward from the centrifuge outlet and be free of sharp bends or traps. On many engines, a crankcase door can be modified to provide a suitable drain opening as well as sturdy mechanical support. Be sure the sump side of the drain opening is clear and that the drain oil does not impinge on moving parts of the engine.

### Mechanical Considerations

Spinner II centrifuges are high-speed devices and should be securely mounted to prevent excessive vibration. Operation up to 10 degrees from vertical is permitted.

### Detailed Information Available

For optimum performance of your centrifuge, specific installation drawings for almost any engine can be requested from your distributor.

All dimensions are in inches

Net weight

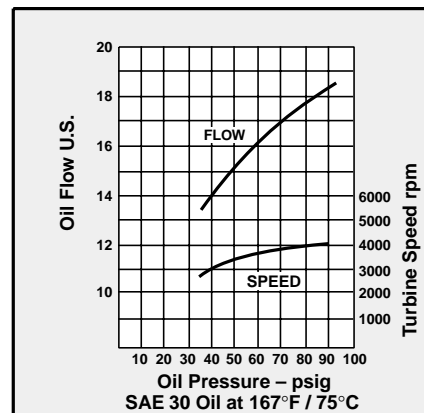
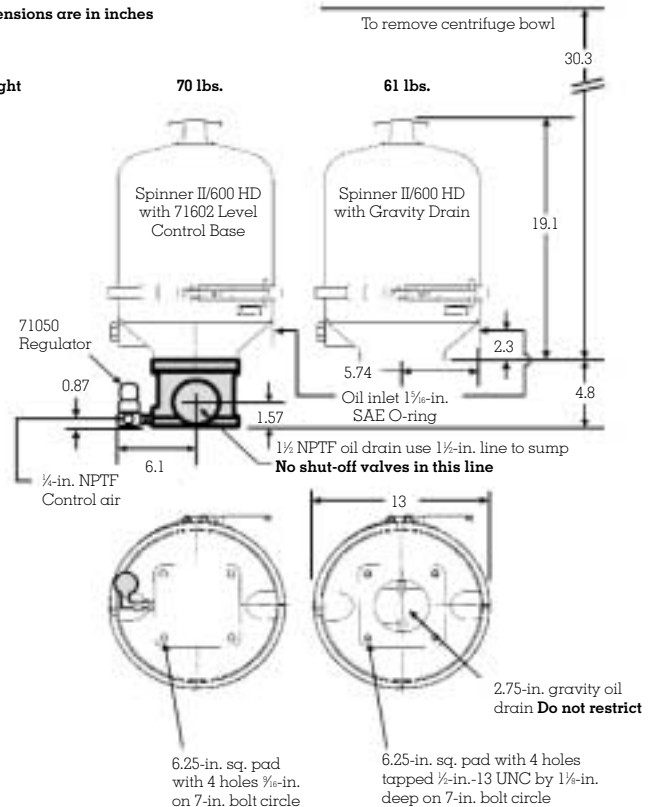

# Model 600 HD Parts List

Description	Part number
Only items shown with part numbers are available. For Type GF600-24 and later. See type nameplate on base.	
<b>Bold denotes assembly</b>	
<b>Centrifuge, Spinner II/600 HD with level control base</b> .....	<b>71567</b>
<b>Centrifuge, Spinner II/600 HD only</b> .....	<b>71563</b>
<b>Cover assembly (no clamp)</b> .....	<b>71565</b>
<b>Cover nut assembly</b> .....	<b>70973</b>
(includes pin, collar and seal)	
Seal-cover nut .....	70971
Clamp with tee handle-cover to base .....	71566
Tee bolt and handle-clamp .....	71522
<b>Centrifuge turbine assembly (includes bowl and turbine)</b> ....	<b>70134</b>
Nut, jacking-centrifuge bowl .....	70545
Washer-jacking nut (2 required) .....	70892
Clip-jacking nut .....	70263
<b>Bearing tube assembly-centrifuge</b> .....	<b>70197</b>
Linear insert (not shown) .....	70185
Seal-centrifuge bowl (Viton®) .....	70886
Stand tube .....	70972
Turbine nozzle (2 required) .....	70211
<b>Base assembly with spindle</b> .....	<b>71564</b>
Seal-base to cover (Viton) .....	70887
<b>Kit cut-out valve repair</b> .....	<b>70728</b>
Seal-idle cut-out valve .....	71523
Tool kit, centrifuge service (optional) .....	71710
Gasket-base flange (not shown, gravity drain only) .....	71959
Fitting-straight inlet 1 $\frac{1}{8}$ -in. SAE x 1-in. female pipe (optional) .....	70956
Fitting-straight inlet 1 $\frac{1}{8}$ -in. SAE x #16 hose (optional) .....	70281
<b>Base-level control with hardware</b> .....	<b>71602</b>
Seal level control base (Viton) .....	70916
Cock-safety drain .....	71057
Kit, repair-control float assembly (not shown) .....	71609
<b>Cartridge-air valve, industrial</b> .....	<b>71603</b>
Regulator-air for 71602 .....	71050

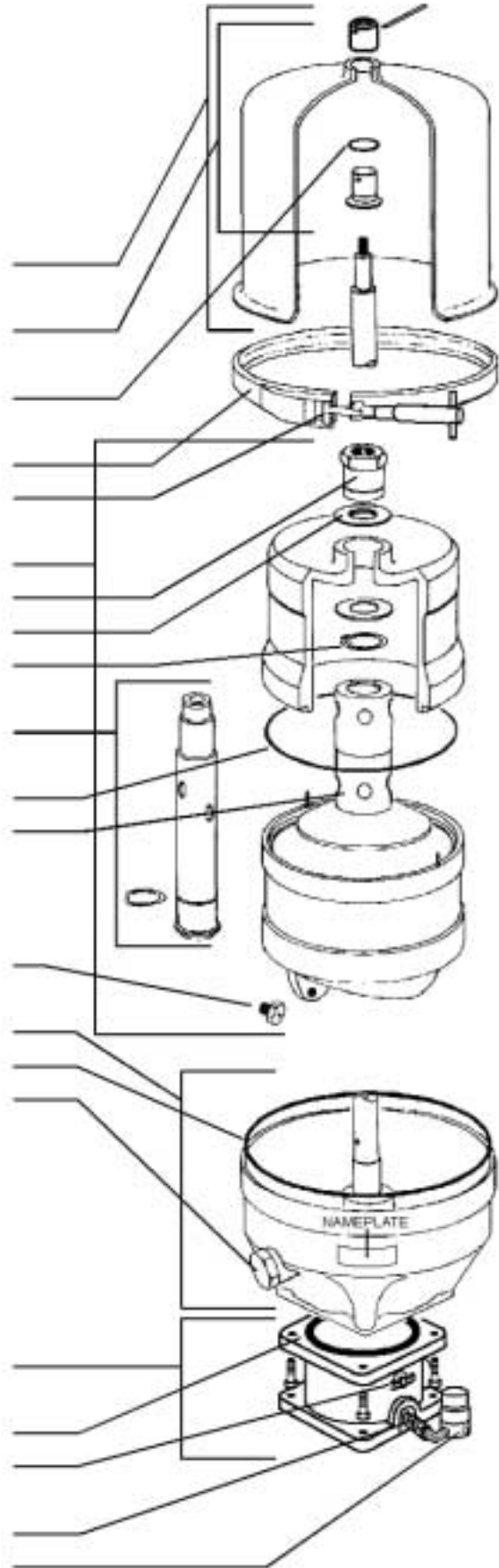

1. Shut off control air. Shut off oil supply (or stop engine) and allow centrifuge turbine assembly to come to a complete stop, drain and cool. **CAUTION:** Open safety drain cock on side of Level Control Base (if equipped) to be certain that unit is not pressurized. If cock is under pressure, locate the source and remove before proceeding. *Check for shut-off valves in the oil drain line and remove if found.*
2. Remove cover clamp, unscrew cover nut and remove cover assembly.
3. Partially withdraw centrifuge turbine assembly from the housing and allow oil to drain from nozzles before removing completely. Carefully separate centrifuge bowl from turbine by unscrewing jacking nut. (An optional kit, Part No. 71710, is available to facilitate disassembly and cleaning.) Remove stand tube.
4. Carefully remove sludge from bowl and turbine using a wooden spatula or other non-damaging tool. Wipe out centrifuge bowl and turbine with solvent and wash stand tube and other parts.
5. Clean and examine top and bottom bushings for excessive wear. Replace bearing tube assembly, Part No. 70197, if diameters exceed 0.814-in. (20.68 mm) top or 1.315-in. (33.39 mm) bottom. Check turbine nozzles to ensure free passage of oil. Inspect centrifuge turbine seal and replace if damaged. The seal is Viton and can be reused several times.
6. Seat stand tube in turbine and reassemble centrifuge making sure that large and small dowel pins in turbine align with matching holes in bowl as jacking nut is tightened. Continue tightening until bowl is seated snugly on turbine. **Do not exceed 74 lb-ft torque** on the jacking nut Part No. 70545.
7. Examine spindle journals for damage or excessive wear. Replace base assembly (complete with spindle) if diameter is less than 0.810-in. (20.57 mm) top or 1.309-in. (33.26 mm) bottom. Spindle is assembled to base and aligned at the factory and cannot be properly serviced in the field.
8. If Level Control Base is used: check control mechanism by using a thin wire with a hook formed on one end to engage float arm on bracket side. Raise float. Air should flow into control mechanism. Air flow should stop when float is lowered. If air control is defective it must be repaired using Part No. 71603 (air valve cartridge kit) or Part No. 71609 (float assembly kit), following the instructions in the kits.
9. Replace centrifuge turbine assembly on spindle, *being careful of the bushings.* Be sure it rotates freely.
10. Clean and inspect cover, paying special attention to cover nut assembly. The seal, PN 70971, should be replaced if it shows signs of leaking. Note: to disassemble, remove roll pin and the collar from the top and withdraw the nut from the bottom.
11. Clean and examine the base-to-cover seal and replace if damaged. The seal is Viton and can be reused several times.
12. Replace cover assembly and tighten cover nut securely *by hand pressure only.* Make sure that cover seats on base assembly evenly all around so that cover seal is properly compressed. Replace cover-to-base clamp and tighten the clamp nut securely by hand. Check all centrifuge and LCB mounting bolts for proper tightness.
13. Close safety drain cock on LCB. Open air supply and oil supply to centrifuge. With engine running, check all connections and joints for leaks. Repeat assembly if vibration is excessive.

**Note:** All centrifuge turbines are correctly balanced before leaving the factory. An out-of-balance condition can occur as a result of uneven build-up of sludge in the bowl or as a result of excessive bearing or spindle journal wear. Depending on conditions, wear will eventually take place on the spindle and bearings which will require replacement of the appropriate assemblies.

### Sales and Service

**SPINNER II®**  
**PRODUCTS**



**T. F. HUDGINS**  
INCORPORATED

Tel: 713-682-3651 or 800-231-7746  
Fax: 713-681-9702  
Mail: P.O. Box 920946  
Houston, Texas USA 77292-0946  
Warehouse: 4405 Directors Row  
Houston, Texas USA 77092  
Web Site: [www.Spinnerii.com](http://www.Spinnerii.com)