

Fill-For-Life Oil Service on Drill Rig Gen Sets

Spinner II® Centrifuges are the key



Spinner II® Profit Builder No. 112
Helpful Sales Tools for Representatives of Spinner II Products

Scenario

In the oil and gas industry, few organizations have been as enduring and recognized as one international drilling contractor and operator headquartered in Dallas, Texas. In dominating the industry, this contractor has been the source for significant operating innovations.

Since the early 1970's, this contractor has made a firm commitment to two key components: the Caterpillar diesel engine and the Spinner II oil-cleaning centrifuge. With this engine, serviceability is high and the Spinner II centrifuge is the ideal complement for efficient contaminant control and engine durability. According to company maintenance personnel, if the engine is a Cat — and it has a Spinner II centrifuge — they are confident of cost-saving performance.

One example of this confidence occurred over six years ago. The corporate Drilling Maintenance Manager approached a synthetic lubricants manufacturer with a proposal: Since our gen set lube oil is kept clean with Spinner II centrifuges, why can't we begin a fill-for-life lube service practice, adding nothing more than make-up oil?

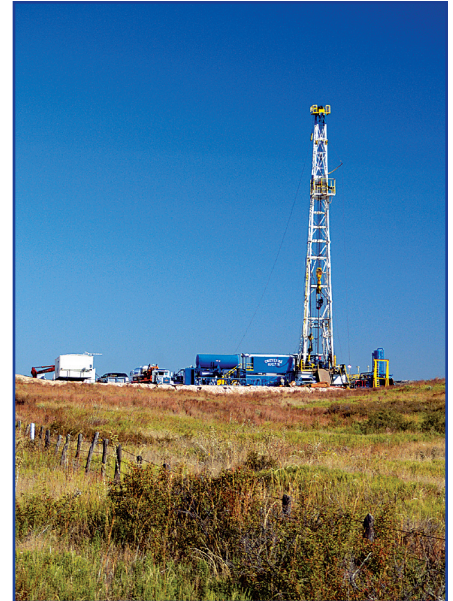

Solution

The fill-for-life concept seemed like a logical approach since these gen sets operate continuously at a fixed speed and load. The lube supplier, Primrose Oil Company, cautioned that despite the impressive endurance of synthetic lubes, chemistry would remain a life-limiting factor. The supplier proposed the triggered addition of the specific additives required for proper maintenance of essential lube characteristics. Formulated after a three-year field development program on drill rigs world-wide, Primrose now packages this Additive Replenishment Kit (ARK) and the fill-for-life approach is offered by the contractor across all its platforms.

Results

The end result of this innovative approach is convincing. Individual engines with the fill-for-life lube practice are approaching 40,000 hours. Total fleet-wide time with the practice exceeds 2,000,000 hours. With lube performance maintained by ARK additions and centrifugal contaminant removal, the fill-for-life practice saves the company significant handling and transport costs since used engine oil never makes the round trip back to recycling facilities.

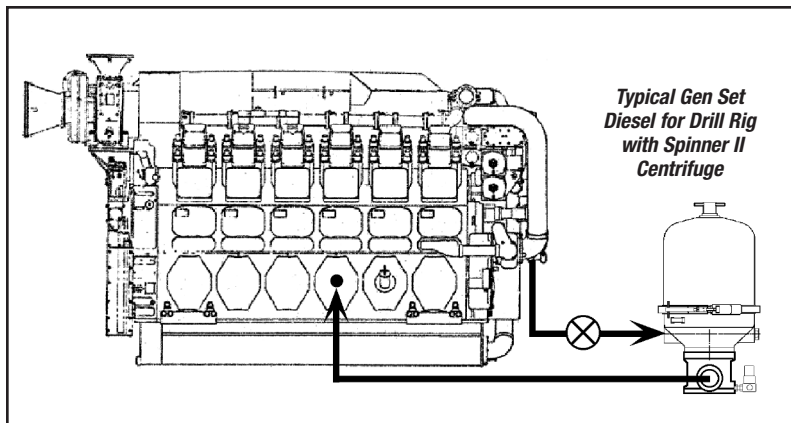

SPINNER II® PRODUCTS



P.O. Box 920946
Houston, Texas 77292-0946
Toll-free: 800-231-SPIN (7746)
Tel: 713-682-3651
Fax: 713-682-9702
www.SpinnerII.com

©Spinner II and Xtreme Cleaning are marks of T.F. Hudgins, Incorporated Patented worldwide.
©2007 T.F. Hudgins, Incorporated All rights reserved.

Xtreme Cleaning™